



# Accident Prevention by Observing Bridge Structural Health

Ms. Shubhangi Bhosale<sup>1</sup>, Mr. Aniket Kale<sup>2</sup>

Student BE, ETC Department, DACOE, Karad, Maharashtra, India<sup>1</sup>

Assistant Professor, ETC Department, DACOE, Karad, Maharashtra, India<sup>2</sup>

**Abstract:** The proposed system and implemented using a real time wireless network for bridge structural health monitoring system the main use of this system is of lossless data transmission over few minutes of continuous. This system is used mainly send the environment parameters for observation and to maintain the fettle of bridge. The main challenge is to ensure that the fettle of civil infrastructure bridge is capable of can resist the accumulate weight of all the vehicles that travel in the bridge. Bridges are most important part of society's infrastructure and secure methods are necessary to monitor them and ensure their safety and efficiency. Bridges contaminate with age and early find out the damage helps in extending the lives and prevent fortunate failure. Most bridges still in used today were built decades ago and are now subjected to changes in load patterns, which can cause localized distress and if not corrected can arise in bridge failure. Recent fortunate bridge failures clearly indicate the urgent need for improving interval-based examination procedures that are qualitative and subjective in nature.

**Keywords:** 89C51 Microcontroller, vibration sensor, scour sensor, GSM.

## I. INTRODUCTION

A measure concern with large civil infrastructure such as bridges, dams, tunnels, etc. is in the valuation of their integrity in relation to the load-carrying capacity due to aging/usage diminution and the occurrence of damage events throughout the life time of structure. The advancement in wireless technology has provided motives to the authors to develop the wireless network based bridge health monitoring system. In this research, sensor devices such as accelerometer, scour sensor and GSM.

Monitoring the damages in the bridge is in concern for the benefit for the public. The vibration sensor is used to identify the internal and external damages. If damage is detected via GSM communication the damage detection is informed to the base station. Bridge health monitoring defines available to monitor bridge health. In addition to this different type of sensing systems, there are other terms capable to bridge health monitoring, as well as the methods and capabilities of the various sensing systems, when choosing a system to meet the bridge needs. Increase in traffic, in urban and rural areas, creates more pressure on the bridge networks than was originally intended.

Bridge engineers require a responsible way to importance of the structural integrity of bridges to maintain the continuous operation of road network while ensuring the safety of the public. Traditional visual inspection methods are both time consuming and costly. They are also qualitative and can only importance of outward appearance. Any internal damage may ignore for a long period of the time. This system can detect changes in the bridge superstructure and in some cases predict impending

failures. This system can monitor bridges in real time and warn state engineers of possible problems to avoid tragedies like collapse.

## II. PROPOSED SYSTEM

The proposed system an implemented using a real time wireless network for bridge health monitoring system the main advantage of this system is of lossless data transmission over few minutes of continuous. This system is used mainly transmit the environmental condition for observation and to maintain the condition of bridges. Vibration sensor is used to detect internal and external faults. If fault is identify via GSM communication the fault detection is informed to the base station. Scour sensor is used to detect sand mining.

This system includes the GSM module for long and short distance wireless data communication which is mobile phone carrier network. This system also uses sensor and interface LCD for displaying output of sensors.

## III. HARDWARE REQUIREMENTS

- i. Microcontroller AT89C51
- ii. Vibration Sensor(ADXL 335)
- iii. Scour Sensor
- iv. A to D Converter
- v. MAX232 IC, Cable
- vi. GSM
- vii. LCD
- viii. Relay Driver



#### IV. BLOCK DIAGRAM

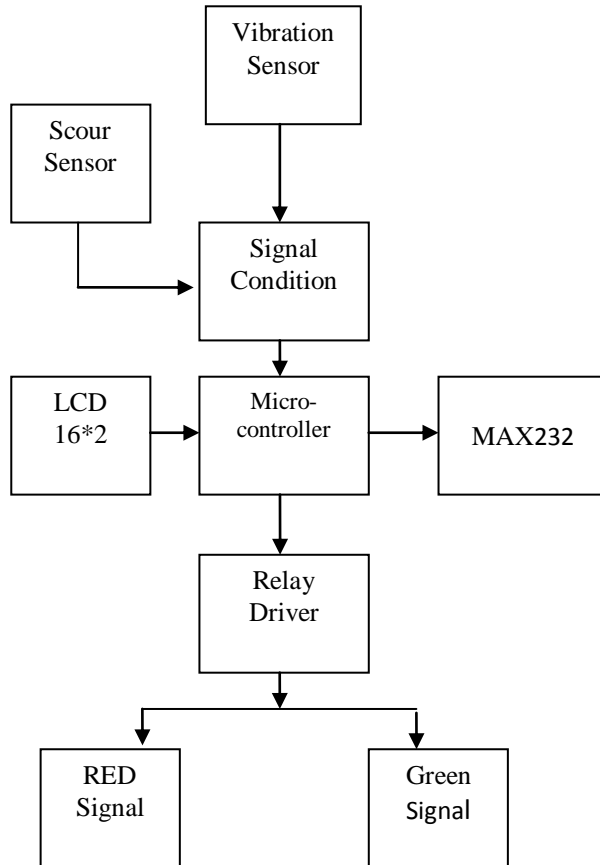

Fig: Block Diagram for Proposed System

#### V. WORKING

A multifunctional wireless bridge health monitoring system has been developed for concurrent arrangement of vibration sensor and scour sensor. A scour comes when water flows at fast rates around the bridge piers or can produce volatility in the bridge. The ADXL335 is a small, thin, low power, complete 3-axis accelerometer with signal conditioned voltage outputs. The output of the vibration sensor in the analog form is given to the microcontroller through the signal conditioner. The signal conditioner is used as an analog-to-digital converter. A relay driver IC is an electromagnetic switch that can be used whenever we want to use a low voltage circuit to switch a light bulb ON and OFF which is connected to 230V. The MAX232 receiver converts TIA/EIA-232-F inputs to 5V TTL/CMOS levels. If a fault is detected via GSM communication, the fault detection is informed to the base station.

##### A. Power supply:

For our project, we require a +5V power supply. This power supply can be designed using a voltage regulator IC 7805.

##### B. MAX232 IC:

The MAX232 device is a dual driver/receiver that includes a capacitive voltage generator using four capacitors to supply TIA/EIA-232-F voltage levels from a single 5-V supply. Each receiver converts TIA/EIA-232-F inputs to 5V TTL/CMOS levels. These receivers have a typical threshold of 1.3 V, a typical hysteresis of 0.5 V, and can accept  $\pm 30$ -V inputs. Each driver converts TTL/CMOS input levels into TIA/EIA-232-F levels.

##### C. AT89C51 Microcontroller:

The AT89C51 is a low-power, high-performance CMOS 8-bit microcontroller with 4Kbytes of in-system programmable Flash memory. The device is manufactured using Atmel's high-density nonvolatile memory technology and is compatible with the industry-standard 80C51 instruction set and pin out.

##### D. Vibration Sensor (ADXL 335):

The ADXL335 is a small, thin, low power, complete 3-axis accelerometer with signal conditioned voltage outputs. The product measures acceleration with a minimum full-scale range of  $\pm 3$  g. It can measure the static acceleration of gravity in tilt-sensing applications, as well as dynamic acceleration resulting from motion, shock, or vibration.

##### E. Scour sensor:

Generally, scour takes place during times of flooding when fast moving water accelerates near bridge piers due to contraction of the channel, and the current carries away sediment near the pier foundation (Lu 2008). Permanent scour detection devices must be able to withstand the large current and debris associated with flooding. The scour sensor, sliding magnetic collar (SMC), which uses a collar that slides down to the river bed and measures depth.

##### F. ADC 0808:

An analog-to-digital converter (ADC, A/D, or A to D) is a device that converts a continuous physical quantity (usually voltage) to a digital number that represents the quantity's amplitude.

##### G. GSM:

GSM (Global System for Mobile communications) is an open, digital cellular technology used for transmitting mobile voice and data services.

GSM supports voice calls and data transfer speeds of up to 9.6 kbps, together with the transmission of SMS (Short Message Service). GSM operates in the 900MHz and 1.8GHz bands in Europe and the 1.9GHz and 850MHz bands in the US. GSM services are also transmitted via 850MHz spectrum in Australia, Canada and many Latin American countries. The use of harmonized spectrum across most of the globe, combined with GSM's international roaming capability, allows travelers to access the same mobile services at home and abroad. GSM



enables individuals to be reached via the same mobile number in up to 219 countries.

## VI. SOFTWARE REQUIREMENTS

- i. Keil Microvision3
- ii. Proteus

## VII. CONCLUSION

A multi-functional bridge monitoring system has been developed for concurrent deployment of accelerometers and scour sensor. The sensing capabilities of these nodes satisfies the immediate requirements for economic, low maintenance load ratings and short term dynamic measurements in addition to providing the hardware functionality for development of long term continuous bridge monitoring system.

## VIII. APPLICATIONS

- i. It is use to measure the bridge tilt.
- ii. It can be use for structural health, bridge safety, damage detection.
- iii. It can avoid accidents caused by extreme weather conditions.
- iv. It is useful for monitoring the faults of bridge occurred.

## REFERENCES

- [1] Vinodini R , Nalini S, Muthumurugesan D,” Detection Of Structural Damages In Bridge Based On ZigBee Networks Using Sensors” IJCSI International Journal of Computer Science Issues, Vol. 10, Issue 3, No 1, May 2013.
- [2] 1Arunkumar.G.C, 2Chandrakanth .S. R, 3Chethankumar.M, 4Karthik.V, 5Santosh Chavan “Bridge Condition Monitoring System Using Wireless Network” Dept. of ECE, RRCE, Bengaluru.
- [3] Mr.M.V.N.R.P.Kumar1,Ms.B.Hombal2, Miss. J.D. Kadam3, Mr. A. B. Yadav4, Mr. B.M. Pawar5. “Bridge Condition Monitoring System Using PIC Microcontroller” Dept. Of E&TC, L.N.B.C.I.E.T. Raigaon, Satara.(Maharashtra) International Journal of Research in Advent Technology, Vol.3, No.5, May 2015.
- [4] SakibMehmud Khan, SezAtamturktur, MashrurChoudhury “Integration Of Structural Health Monitoring and Intelligent Transportation Systems for Bridge Condition Assessment: Current Status and Future Direction” IEEE Transaction on Intelligent Transportation Systems, Vol.17,No.8, august 2016.
- [5] Merit Enckell , BrankoGlisic ,Frank Myrvoll ,Benny Bergstrand “Evaluation of a large-scale bridge strain, temperature and crack monitoring with distributed fiber optic sensors” Received: 29 October 2010 / Accepted: 6 February 2011 / Published online: 3 March 2011.
- [6] Edward Sazonov, Member, IEEE , Haodong Li, Member, IEEE, Darrell Curry, and PragasenPillay, Fellow, IEEE ” Self-Powered Sensors for Monitoring of Highway Bridges” Sensors Journal, IEEE, vol. 9, 2009, pp. 1422-1429.
- [7] Matthew J. Whelan, Michael V. Gangone, Kerop D. Janoyan, and Ratneshwar Jha, “Wireless Vibration Monitoring for Damage Detection of Highway Bridges”, Clarkson University, Department of Civil and Environmental Engineering 8 Clarkson Ave, Box 5710, Potsdam, NY 13699, c 2011 SPIE.